

SINGLE FIXTURE CAGE

ARKADIUM

FEATURES

- Self contained single cage
- Protects lighting fixtures from damage.
- Fabricated from welded .5" tube steel
- Painted flat black
- Can be hung from 1 1/2" schedule 40 steel pipe
- Provide easy access to fixture for focusing and bulb replacement.
- Suitable for Strand Lighting and ETC ellipsoidal fixtures

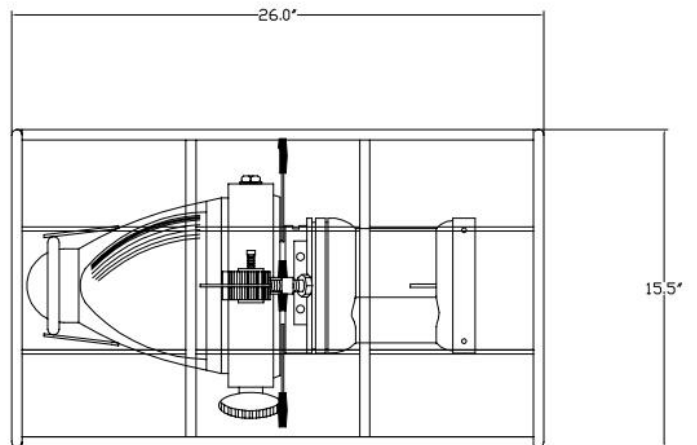

APPLICATION USES

School gymnasiums
Multi-purpose rooms

DIMENSIONS

26" L X 15.5" H X 15.5" W

WEIGHT

Three (3) lbs.

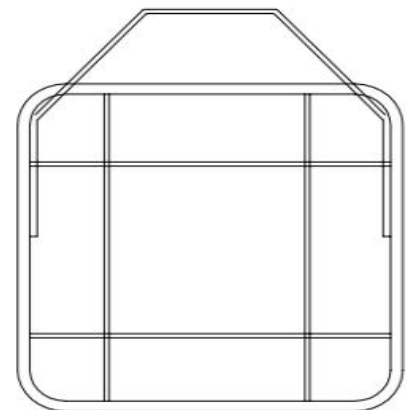
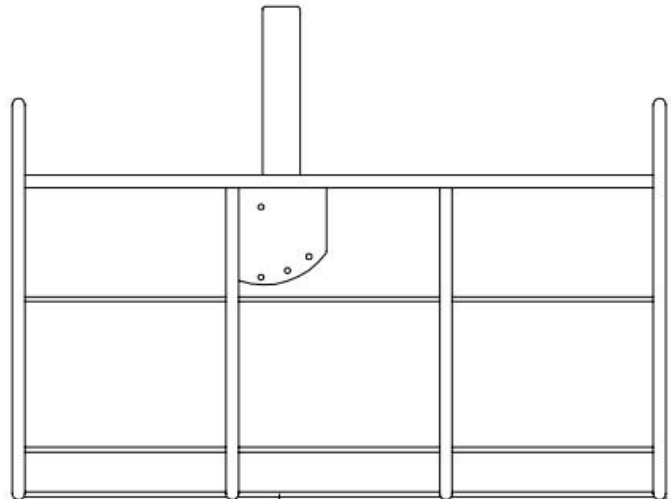

ARKADIUM

67 Watson Road South Unit #7

Guelph, Ontario N1L 1E3

Tel: (519) 837-8367 Fax: (519) 837-2487 www.arkadiumdistro.com

The Company reserves the right to make any variation in design or construction to the equipment described.