

# CHANNEL MOUNT CIRCUIT RACEWAY

# ARKADIUM

*Extruded Aluminum  
Raceway for circuit  
distribution and  
fixture mounting*

## FEATURES

- Channel mount is listed by CSA
- Finished flat black as standard
- Non ferrous construction prevents AC induced noise or vibration
- Rugged pre-wired distribution system for feeding lighting equipment vertically or horizontally. Circuits are wired home run, receptacle to terminal strip for ease of installation and wiring
- Light weight for rigging load advantage
- Splice bars are supplied to ease assembly of long channel mounts segmented for ease of shipping
- A variety of hangers are available to suit most installations. Single and double pipe hangers are designed to accept 1 1/2" ID schedule 40 pipe as the lighting instrument mounting system when using fixtures with standard "c-clamps"
- Available with 20A twist lock or 15A u-ground receptacles either flush mounted or "pig tail" - hanging on 18" flexible cable. Medium screw base swivel mount lamp holders may be specified.

## CHANNEL MOUNT CIRCUIT RACEWAY

Channel Mount is a custom built plug in strip and wire way that has options for a lighting instrument mounting system. Made from heavy duty, corrosion resistant extruded aluminum, the Channel Mount system is available in continuous lengths up to ninety (90) feet with a fifty-five (55) circuit capacity. Channel Mount is pre-wired for simple field connections.

## APPLICATIONS

- Theatres
- Television
- Schools
- Auditoriums
- Display Areas
- Museums
- Galleries

## ARKADIUM

67 Watson Road South Unit #7

Guelph, Ontario N1L 1E3

Tel: (519) 837-8367 Fax: (519) 837-2487 [www.arkadiumdistro.com](http://www.arkadiumdistro.com)

The Company reserves the right to make any variation in design or construction to the equipment described.

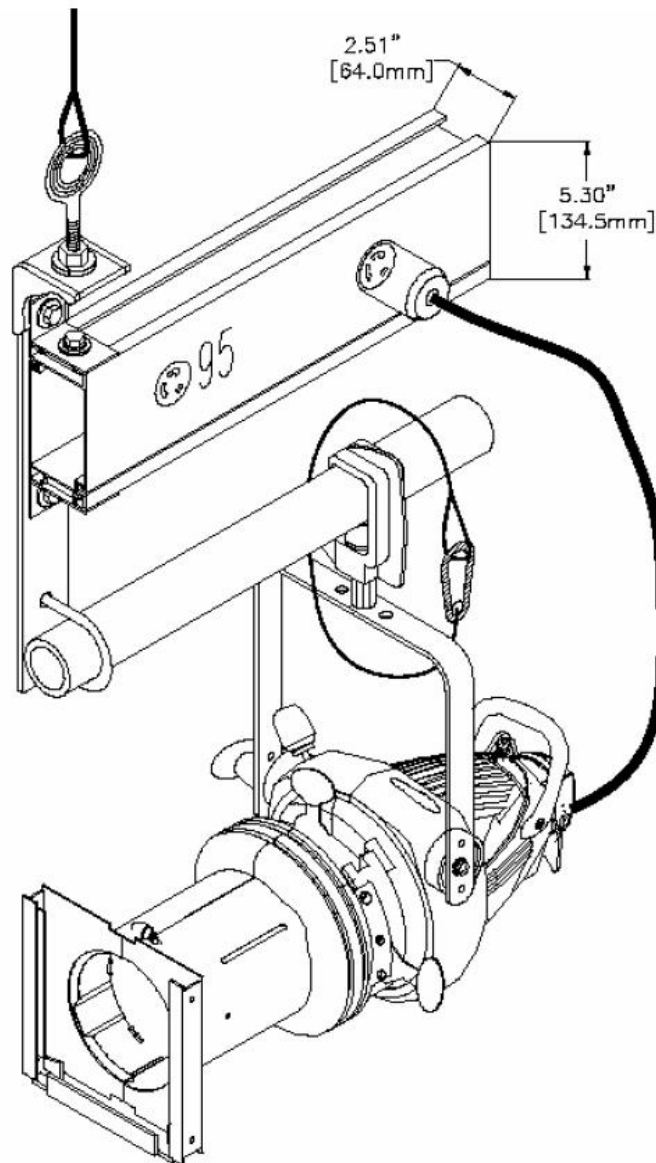

MADE  
IN  
CANADA

CSA File No. LR27919

# CHANNEL MOUNT CIRCUIT RACEWAY

# ARKADIUM

*Extruded Aluminum  
Raceway for circuit  
distribution and  
fixture mounting*

*Hanging and Mounting Solutions*

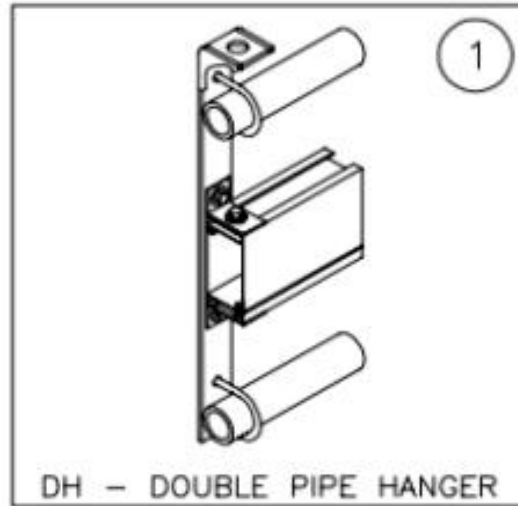
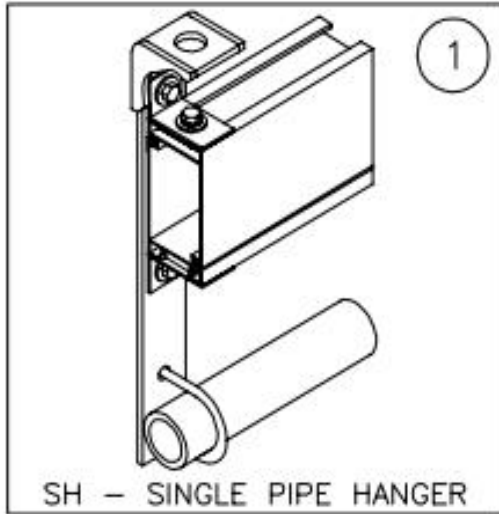

Single pipe Hanger (load method #1) (can be used as grid hanger above pipe) and Double Pipe Hanger are designed to carry fixture load on the pipe only.

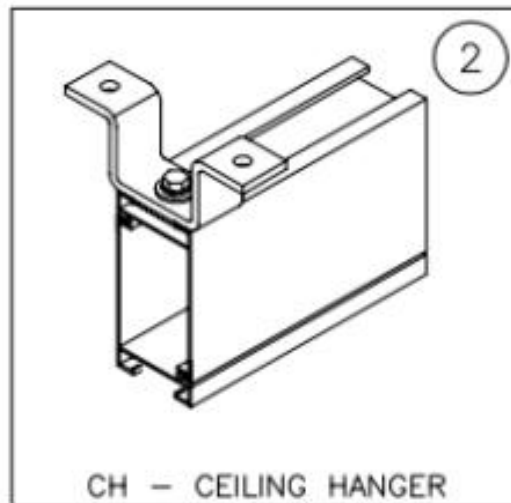
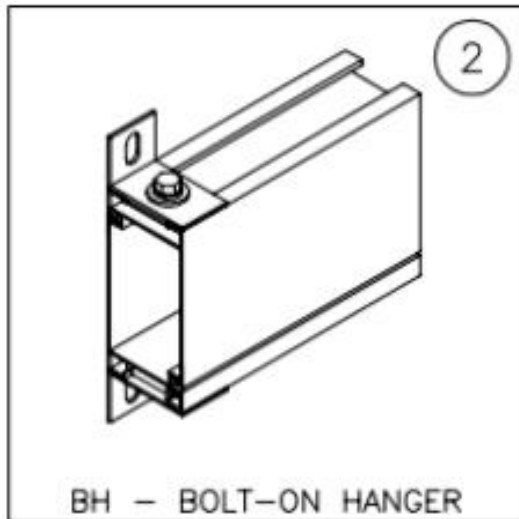

Bolt On Hanger and Ceiling Hanger are not designed to carry fixture loads.

ARKADIUM

67 Watson Road South Unit #7

Guelph, Ontario N1L 1E3

Tel: (519) 837-8367 Fax: (519) 837-2487 [www.arkadiumdistro.com](http://www.arkadiumdistro.com)

The Company reserves the right to make any variation in design or construction to the equipment described.

# CHANNEL MOUNT CIRCUIT RACEWAY

# ARKADIUM

*Extruded Aluminum  
Raceway for circuit  
distribution and fixture  
mounting*

*Hanging and Mounting Solutions*

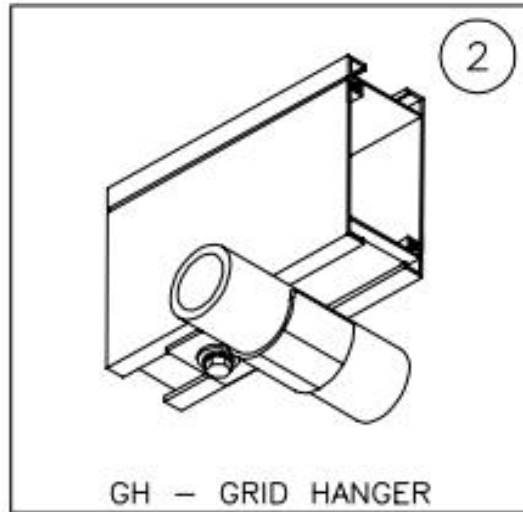
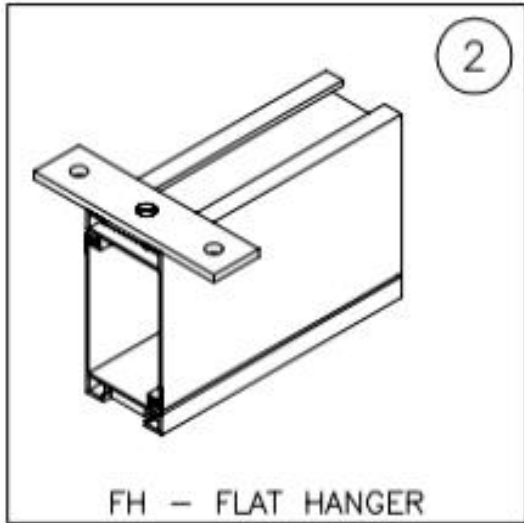

Flat Hanger and Grid Hanger are not designed to carry fixture loads.

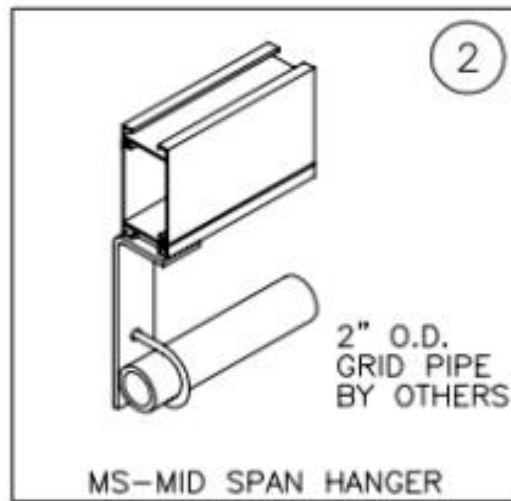
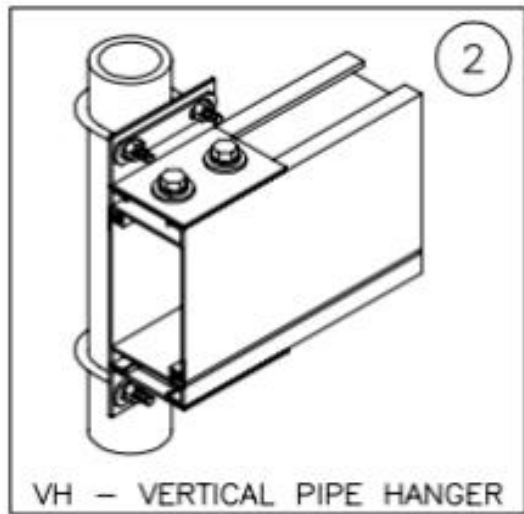

Vertical Pipe Hanger and Mid Span Hanger are not designed to carry fixture loads.

ARKADIUM

67 Watson Road South Unit #7

Guelph, Ontario N1L 1E3

Tel: (519) 837-8367 Fax: (519) 837-2487 [www.arkadiumdistro.com](http://www.arkadiumdistro.com)

The Company reserves the right to make any variation in design or construction to the equipment described.